

# HabasitLINK<sup>®</sup>

## Installation instructions for belt types M2540, M2543, M2544

Please find full installation guide on [www.habasitlink.com](http://www.habasitlink.com)

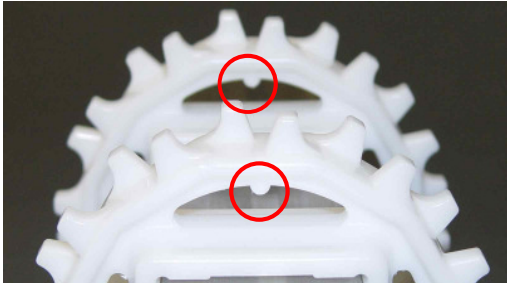

### Sprocket alignment on the shafts:

Corresponding teeth axial aligned, check by alignment mark.

If the bore is square and the number of teeth can be divided by 4, there may be no mark.

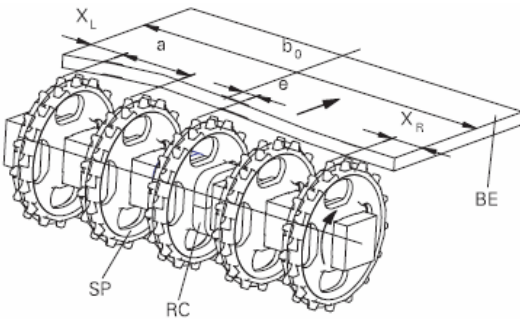

### Sprockets Positioning:

Place sprockets between min. and max. spacing (a).

Offset (e) given by shaft design.

Fix only the sprocket in the middle with small clearance.

| Belt type                                   | Sprocket spacing a    |                       | Edge distance* (minimal)     |                              |
|---|-----------------------|-----------------------|------------------------------|------------------------------|
|   | minimal<br>mm<br>inch | maximal<br>mm<br>inch | X <sub>L</sub><br>mm<br>inch | X <sub>R</sub><br>mm<br>inch |
| M2540                                       | 50<br>2               | 117<br>4.6            | 21<br>0.8                    | 29<br>1.15                   |
| M2540 with hold<br>down tabs                | 50<br>2               | 117<br>4.6            | 54<br>2.13                   | 62<br>2.44                   |
| M2540 MTW<br>mold to width<br>and bricklaid | 50<br>2               | 117<br>4.6            | 41<br>1.6                    | 49<br>1.93                   |
| M2543                                       | 50<br>2               | 117<br>4.6            | 26<br>1                      | 35<br>1.38                   |
| M2544                                       | 50                    | 117                   | 33                           | 42                           |

\* X<sub>L</sub> and X<sub>R</sub> are related to running direction A and are inverse for the running direction B

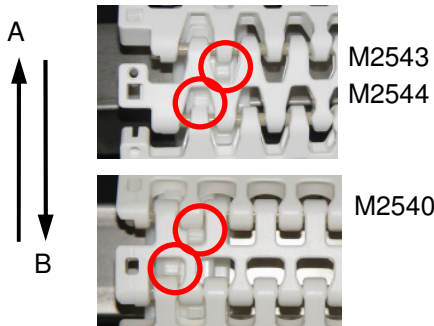

### Belt running direction:

These belts can run in both directions but it might be given by the shaft design with fixed sprocket and offset (e). Install the belts whenever possible with rod head on the outside of the curve.

Preferred running direction for radius conveyors is A. For Spiral conveyors it is direction B.

Respect minimal edge distance X<sub>L</sub> and X<sub>R</sub> depending on running direction.

### Check proper sprocket engagement:

The sprocket teeth must properly engage in the belt.

Belt reverse side is in contact with the sprocket rim.

Check proper sprocket engagement from belt surface.

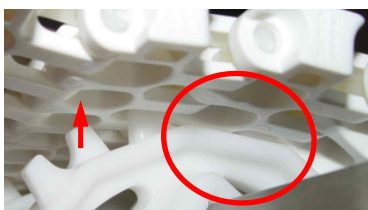

### Rod installation (snap fit rod retention):

Rod Ø5mm (0.2") with round shaped head must have a beveled end. Install the belt with rod head on the outside of the curve. In case of more curves with opposite direction install belt with rod head on outside at last curve (closer to head drive), for wide belts there might be two rods per row (S-curve).

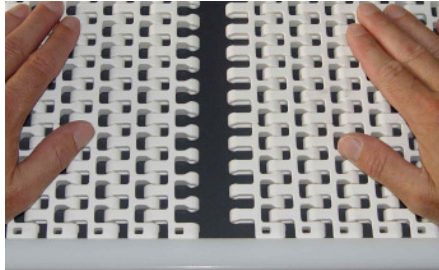

Pull belt sections together

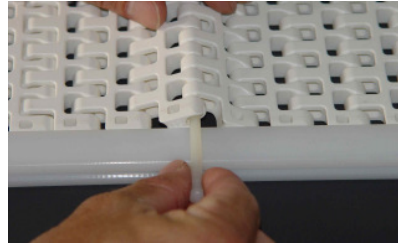

Insert rod

For easy rod installation, rod end must be beveled.

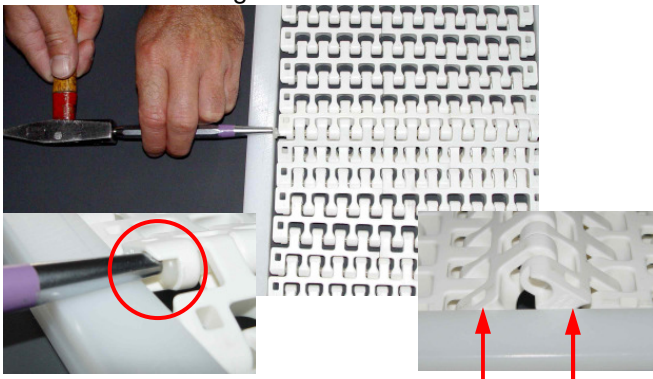

For proper rod installation use hammer and punch.

Hold back module edge at opposite.

Check if rod head is fully embedded.

### Rod removing (snap fit rod retention)

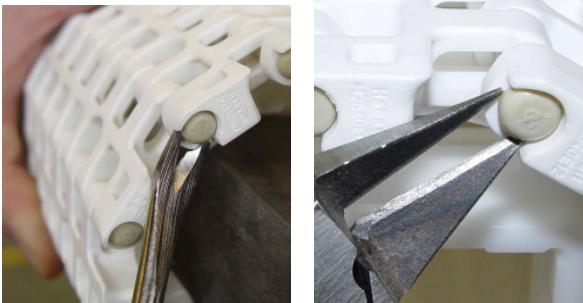

Leverage rod head out

### Rod removal by Habasit rod removal tool (rod puller) or side cutter.

Do not cut off the rod head.

The belt must not be under tension.

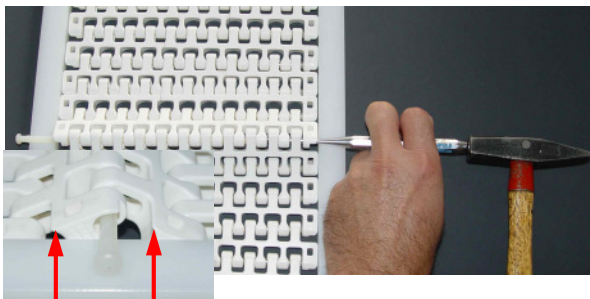

### Rod removal by hammer and punch.

Punch out of retaining head by striking rod end opposite to retaining head.

Hold back module edge on the opposite side.

The belt must not be under tension.

### Product liability, application considerations

If the proper selection and application of Habasit products are not recommended by an authorized Habasit sales specialist, the selection and application of Habasit products, including the related area of product safety, are the responsibility of the customer. All indications / information are recommendations and believed to be reliable, but no representations, guarantees, or warranties of any kind are made as to their accuracy or suitability for particular applications. The data provided herein are based on laboratory work with small-scale test equipment, running at standard conditions, and do not necessarily match product performance in industrial use. New knowledge and experiences can lead to modifications and changes within a short time without prior notice.

BECAUSE CONDITIONS OF USE ARE OUTSIDE OF HABASIT'S AND ITS AFFILIATED COMPANIES' CONTROL, WE CANNOT ASSUME ANY LIABILITY CONCERNING THE SUITABILITY AND PROCESS ABILITY OF THE PRODUCTS MENTIONED HEREIN. THIS ALSO APPLIES TO PROCESS RESULTS / OUTPUT / MANUFACTURING GOODS AS WELL AS TO POSSIBLE DEFECTS, DAMAGES, CONSEQUENTIAL DAMAGES, AND FURTHER-REACHING CONSEQUENCES.

